

ru·ral broad·band - \•rur-əl\ \•brod-•band\

Function:

noun

Date:1960

1 : operating at, responsive to, or comprising a wide band of frequencies in a open area
2 : of, relating to, (AMI) ADVANCED METER INFRASTRUCTURE, (DA) DISTRIDUTION AUTOMATION, (DSM) DEMAND SIDE MANAGEMENT, (HAN) HOME AREA NETWORK, 2009 ARRA, AWARENESS, BROADBAND DEPLOYMENT, BSI, BUSINESS-TO-BUSINESS COMMERCE, CHILDREN, CO-LOCATE, COMMUNITY CENTERS, COMPUTER TRAINING CENTER, DATA CENTER, DEDICATED FIBER, ECONOMICAL, ECOSYSTEMS, EXPANDABILITY, FIBER BACKBONE, FIBER RING, FIBER-BASED NETWORK, FTTH NETWORK, FUTURE-PROOF NETWORK, HEALTHCARE DELIVERY, HFC NETWORK, HIGH-SPEED, HOMELAND SECURITY, INFORMATION SUPER HIGHWAY, INFRASTRUCTURE, INTEROPERABILITY, JOB CREATION, JOB RETENTION, JOBS, LINEMEN, LOAD MANAGEMENT, Mbps, MEGABITS, MESH WIFI, NETWORK ARCHITECTURE, NETWORK OPERATION CENTER, NETWORK RELIABILITY, NEXT GENERATION 9-1-1, OPTICAL BACKHAUL, PROJECT MANAGEMENT, PROPRIETARY NETWORK, PROVEN TECHNOLOGY, PUBLIC SAFETY, PUBLIC-PRIVATE PARTNERSHIP, ROBUST, RURAL BROADBAND, RURAL MANUFACTURING, SCALEABILITY, SCHOOLS, SECURE PLATFORM, SMART GRID, SUSTAINABILITY, TELECOMMUNICATIONS, TELECOMMUTE, TELEMEDICINE, UPGRADE, VoIP, VULNERABLE POPULATIONS, WEB-BASED COMMERCE, WIRELESS BROADBAND or being a high-speed communications network and especially one in which a frequency range is divided into multiple independent functions for simultaneous transmission of signals (as voice, data, or video)

RURAL BROADBAND/SMART GRID

DEPLOYMENT PLAN

RURAL BROADBAND DEPLOYEMENT MISSION STATEMENT

Counties, towns, businesses, non-profits, private corporations, state government and other qualified entities to consolidate efforts and work together to deploy future-proof, robust, advanced fiber-based broadband networks in a way that meets or exceeds the goals as set forth in the 2009 American Reinvestment and Recovery Act, and is inclusive of community support organizations, healthcare providers, universities, educational facilities, libraries, institutions, aged and other vulnerable populations.

Fiber to the Premise feeding to public buildings, government facilities, police and fire, schools, hospitals, universities, libraries, community centers and businesses, with a fully redundant wireless platform overlay With 100% coverage of the county area.

This is a “future proof ” redundant fiber based backhaul network architecture, downstream speeds up to 100 megabits per second are attainable on the fiber, and speeds of 2-4 megabits per second are available to all wireless end Users.

PREFERRED SYSTEM ARCHITECTURE

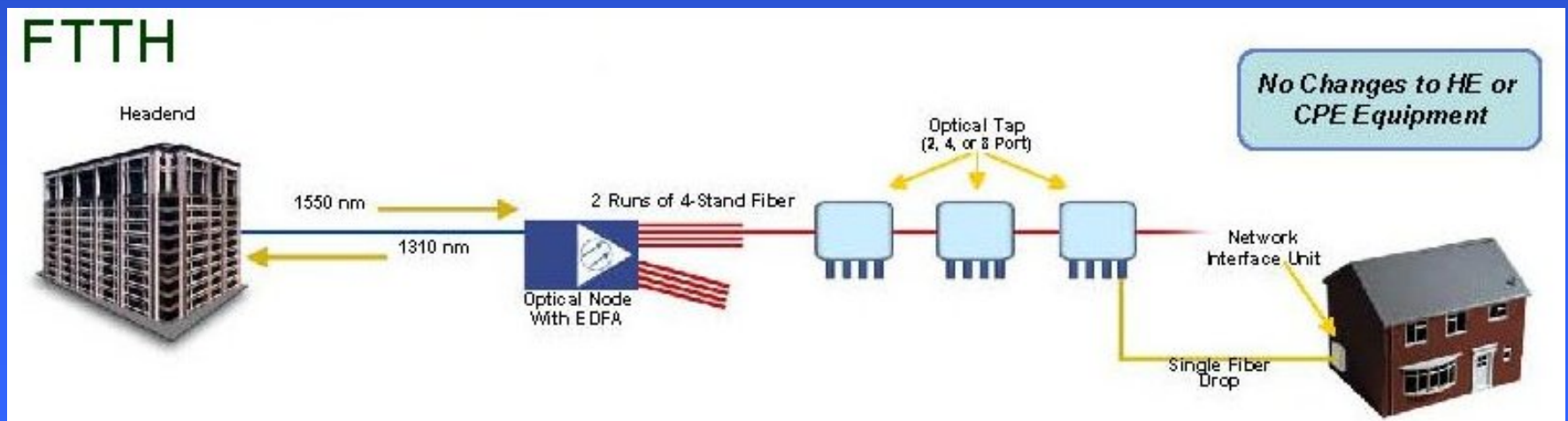



DYNAMIC JOB CREATION & RETENTION

**LINEMEN AND OTHER SKILLED LABOR TO BUILD
NETWORK**

ATTRACT NEW COMPANIES TO AREA

**REOPEN CLOSED BUSINESSES WITH WEB BASED
OPERATIONS**

HUGE ECONOMIC DEVELOPMENT TOOL

GROW EXISTING BUSINESSES

OPERATION, SALES & MARKETING STAFF

BENEFITS OF A FIBER-BASED NETWORK FOR RURAL DEPLOYMENT

Economic Development & Job Creation

Network Reliability & Redundancy

Homeland Security & Public Safety

Interoperable Government Facility Connectivity

Telemedicine & E Medicine

Medical Informational Websites

High Speed Telecommuting

Web-Based Commerce

Future Proof/Expandable/Scalability

Proven Technology & Secure Network

Long Distance Learning

CONSIDER GOING ONE HUGE STEP FURTHER WITH YOUR BROADBAND DEPLOYMENT DEFINITION OF A SMART GRID

Smart Grid is the “convergence of information and operational technology applied to the electric grid allowing sustainable options to costumers and improved security, reliability, and efficiency to utilities”.

Smart Grid deployment will create thousands of sustainable manufacturing and service related jobs to support network systems and operations such as:

Distribution Automation (DA)

Intelligent Equipment Devices (IED)

Advanced Meter Infrastructure (AMI)

NETWORK SMART GRID APPLICATIONS THAT WILL SAVE CONSUMERS AND UTILITIES MONEY

Generation, Transmission & Distribution

Distribution Automation (DA)

Automated Metering Infrastructure(AMI)

Automated Turn On/Off Service

End-User Appliances (Prices to Devices)

Load Management, Substation Equipment Monitoring

Distribution Power Flows, Voltage Measurement

Emergency Grid Management

Reverse Metering Capabilities for Residences and Businesses

Electric Vehicle Battery Power Storage for Sell Back at Peak Usage Times

**Automated Emergency Reroute of Power During Outages to Minimize the
Number of Affected Customers**



INTEGRATING SMART GRID TECHNOLOGY INTO THE BROADBAND NETWORK

Will create sustainable jobs immediately to support the smart grid operations

Will immediately lead to more sustainable use of electric power for economy and to preserve ecosystems

Will save money in the future if deployed widespread, through economic savings gained by utilizing the broadband network for Smart Grid deployment vs. building a proprietary Smart Grid broadband network later

Through savings realized by demand side management of appliances, will provide discretionary spending dollars to end users to put back into the local economy



For more information,

Contact Gerry Locke, Bob Macioch or Mike Davis

Toll Free 1-877-559-0531

broadband.networks@bsicable.com

www.bsicable.com

www.broadbandfleetservices.com

www.broadbandtactical.com

BSI is a HUB/Native American/Woman/Minority Owned Firm.